

# HYPHERPRO

## STEERING DAMPER MOUNTING KIT

for

### YAMAHA YZF-R6 Models '06-'07 / '08-'09

#### MK-YA06-T005 PART LIST

SD stroke 75	1	Spacer D13.5 d8.2 L10.3	1
Damper Clamp (DB0010)	1	Spacer M6 to M8	1
O-Ring	2	M6x100	1
Fork Bracket (FOMK 60)	1	M8x25 Button head	1
Tank Bracket assy (TAMK49)	1	M8x45	1
Tank Bracket washer	1	Washer M6 $\phi$ 18	1
Spacer D15 d6.2 L9	1	Washer M8 $\phi$ 16	2
Spacer D17 d6.2 L14.8	1	Shim (SH-17-6-0.25)	6

ALL IDEAS, DESIGNS ARRANGEMENTS AND PLANS INDICATED OR REPRESENTED BY THIS DRAWING ARE OWNED BY HYPERPRO AND WERE CREATED, EVOLVED AND DEVELOPED FOR USE ON AND IN CONNECTION WITH THE SPECIFIC PROJECT. NONE SUCH IDEAS, DESIGNS, ARRANGEMENTS OR PLANS SHALL BE USED BY OR DISCLOSED TO ANY PERSON, FIRM OR CORPORATION FOR ANY PURPOSE WHATSOEVER WITHOUT THE WRITTEN PERMISSION OF HYPERPRO.

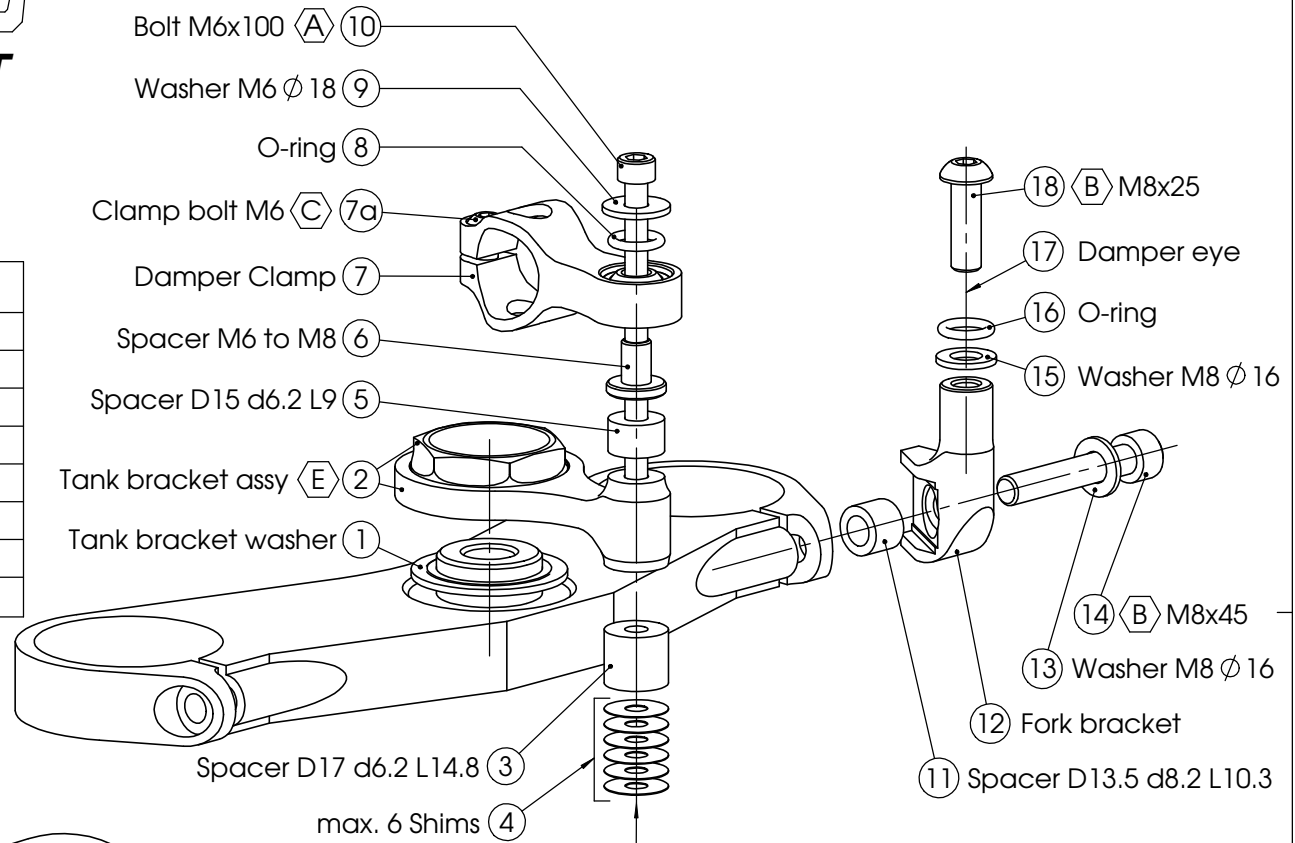

DAMPING ADJUSTER KNOB:  
- turn CW to increase damping  
- turn CCW to decrease damping  
NEVER USE MAXIMUM SETTING !!!

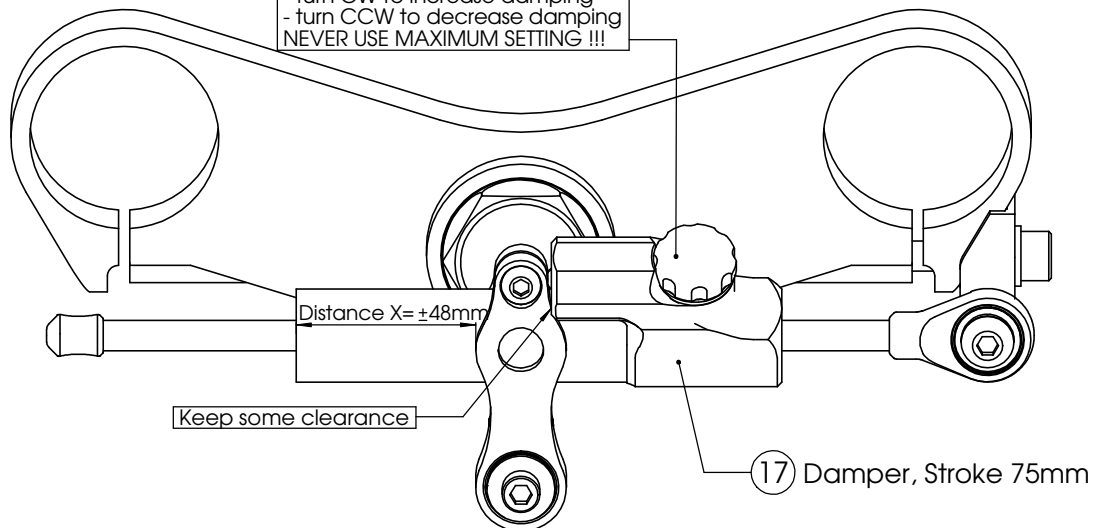

#### \* TORQUES

A: 5-9Nm / 44-80Lbs.In / 4.0-6.4Lbs.Ft  
B: 14-17Nm / 124-150Lbs.In / 10.3-12.5Lbs.Ft  
C: 6Nm / 53Lbs.In / 4.4Lbs.Ft

D: 8Nm / 70Lbs.In / 5.9Lbs.Ft  
E: 55Nm / 486Lbs.In / 40Lbs.Ft  
F: Factory torque (see owners manual)

# HYPERPRO

## STEERING DAMPER MOUNTING KIT

for

### YAMAHA YZF-R6

Models '06-'07 / '08-'09

## MK-YA06-T005 INSTALLATION INSTRUCTIONS

### In general:

HYPERPRO can not be held responsible in any way for any form of physical, material, financial or other damage arising from use, assembly or overhaul of HYPERPRO products. HYPERPRO reserves the right to make changes without prior notice.

This product is ONLY TO BE INSTALLED BY A PROFESSIONAL MECHANIC.

This product is only to be used for the motorcycle brand, model and year stated specifically on top of the pages of this manual.

DO NOT attempt to install this product on motorcycles from any different brand, model and/or year than stated on the pages of this manual.

DO NOT use this kit for cars, boats, jet-skies, snowmobiles, ATV's, aircraft, hovercrafts or any other vehicle and/or purpose.

HYPERPRO steering dampers are FOR RACE USE ONLY, NOT FOR HIGHWAY USE!

### Before installation:

- Please read the entire manual carefully before starting the installation!
- Check if you have all the tools required. Good tools are a must.
- Protect your bike at the most important places in and around the work area (e.g. tank, fairing, frame, etc.), with a blanket, towel or similar.

### During installation:

- Check all operations and parts carefully before, during and after performing each step.
- Clean all surfaces that are required for fitting parts together or for applying self adhesives or loctite, thoroughly with contact cleaner or another degreaser, unless otherwise stated.
- Be careful not to damage or scratch any part of your bike.
- ALWAYS work relaxed and concentrated!! It is very easy to damage something or make a mistake.

### After installation:

- Check and make sure that there is no contact between any part of the steering damper kit and any part of the motorcycle. The kit should not hit anything. Steering movement should not be limited by the steering damper. If the steering movement is limited, adjust the position of the tube in the clamp until steering movement is normal again. Do not forget to tighten the clamp bolt again!
- ALWAYS check the steering movement and feeling before each ride !
- FIRST RIDES: Start with the damper turned fully open (turn adjuster knob fully counter clockwise). Start adjusting in between rides with steps of MAX. 2 CLICKS (0.25 TURN) EACH TIME, until the damper is working satisfactory for your riding style.
- NEVER USE MAXIMUM SETTING, ALWAYS OPEN AT LEAST 2 CLICKS (0.25 TURN).
- WARNING ! DAMPER HAS AN ACTIVE / SPEEDSENSITIVE DAMPING SYSTEM;
  - Steering with NORMAL MOVEMENT should be FREE !!
  - Steering with FAST MOVEMENT should be CONTROLLED BY DAMPER !!
- HYPERPRO uses a special seal to reduce friction. The seal uses an oil film to work properly. It is normal that some oil can appear on the pistonrod.
- Damper works with oil: DAMPING CAN BE HARDER AT LOWER TEMPERATURES!

### Step 1: installing the tank bracket

Install the tank bracket using:

- Tank bracket washer (1)
- Tank bracket assembly (2)
- Spacer D17 d6.2 L14.8 (3)
- Shims D17 d6 0.25 (4)
- Spacer D15 d6.2 L9 (5)
- Damper clamp Type10 (6)
- O-ring (7)
- M6 Washer  $\phi$  18 (8)
- Bolt M6x100 (9)

Remove the standard steering stem nut, the front tank mount bolt and the washers. Place the tank bracket washer (1) over the steering stem and loosely install the tank bracket assy (2).

Tighten the 36mm nut with a torque of 55Nm/486Lbs.In/40Lbs.Ft.

Place the  $\phi$  17 spacer (3) between the tank and the bracket push down on the tank and use enough shims (4) to fill the gap between the spacer (3) and the tank.

Position all other parts (5, 6, 7, 8, 9) on top of the tank bracket, using the M6 bolt (10). Tighten the bolt with a torque of approx. 5-9Nm/44-80Lbs.In/4.0-6.4Lbs.Ft

### Step 2: installing the fork bracket

Install the fork bracket using:

- Spacer D13.5 d8.2 L10.3 (11)
- Fork bracket (12)
- M8 Washer  $\phi$  16 (13)
- Bolt M8x45 (14)

Loosen and remove the righthand fork clamp bolt from the top yoke. Place the  $\phi$  10.3 spacer (11), fork bracket (12), washer (13) over the hole using the supplied M8x45 bolt (14).

Tighten the bolt with a torque of approx. 14-17Nm/124-150Lbs.In/10.3-12.5Lbs.Ft.

### Step 3: installing the steering damper

Install the steering damper using:

- M8 Washer  $\phi$  16 (15)
- 1x O-ring (16)
- Steering damper, stroke 75 (17)
- Bolt M8x25 button head (18)

Ensure that the clamp bolt (7a) of the tube clamp is pointing forward. Shove the damper (17), with the knob-end first, through the clamp until the ball joint can be fitted to the fork bracket. Use the washer (15), O-ring (16) and M8 bolt (18) to fixate the balljoint to the fork bracket and tighten with a torque of approx. 14-17Nm/124-150Lbs.In/10.3-12.5Lbs.Ft. Position the damper tube until the distance "X" stated on page 1 is reached, then tighten the M6 clamp bolt (7a) with a torque of approx. 6Nm/53Lbs.In/4.4Lbs.Ft.

Check if the damper is level horizontally and aligned to the bike, washer (15) can be removed if necessary to improve. Check if the damper does not touch anything (e.g. tank) when steering from left to right. Check if the bike can make it's full steering angle from left to right.