

# HYPHERPRO

## STEERING DAMPER MOUNTING KIT for YAMAHA YZF 600 R6 Race Model 1999 - 2002<

MK-YA06-S001 PART LIST			
SD stroke 160	1	Frame plug	1
Tube Clamp TYPE 1	1	-	-
O-Ring	2	-	-
Fork Clamp $\phi$ 43	1	-	-
Spacer TYPE 1	1	-	-
M8x30 Button head	1	-	-
M8x35	1	-	-
Washer M8 $\phi$ 21 h=4	1	-	-

ALL IDEAS, DESIGNS ARRANGEMENTS AND PLANS INDICATED OR REPRESENTED BY THIS DRAWING ARE OWNED BY HYPERPRO AND WERE CREATED, EVOLVED AND DEVELOPED FOR USE ON AND IN CONNECTION WITH THE SPECIFIC PROJECT. NONE SUCH IDEAS, DESIGNS, ARRANGEMENTS OR PLANS SHALL BE USED BY OR DISCLOSED TO ANY PERSON, FIRM OR CORPORATION FOR ANY PURPOSE WHATSOEVER WITHOUT THE WRITTEN PERMISSION OF HYPERPRO.

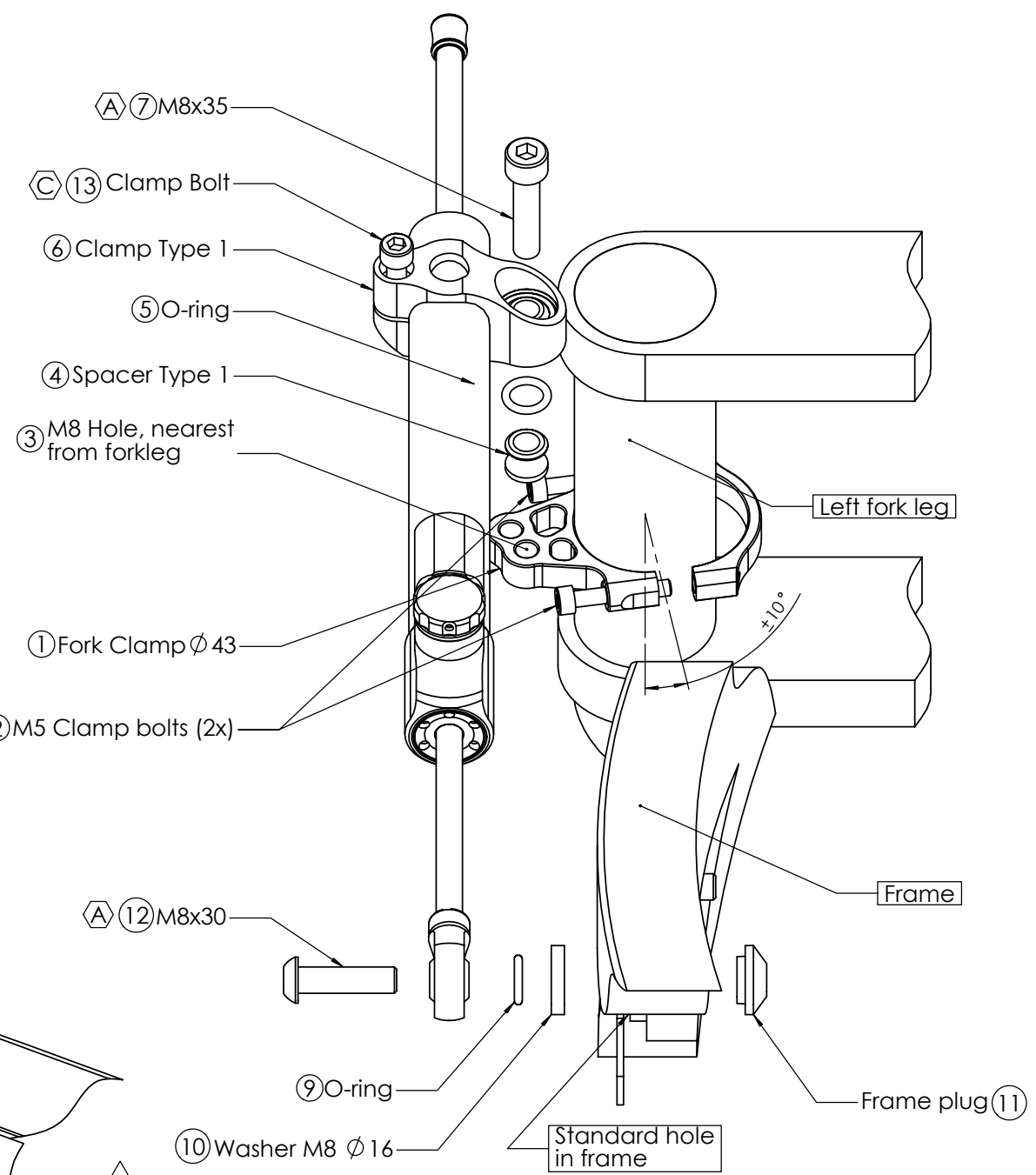

**DAMPING ADJUSTER KNOB:**  
 - turn CW to increase damping  
 - turn CCW to decrease damping  
**NEVER USE MAXIMUM SETTING !!!**

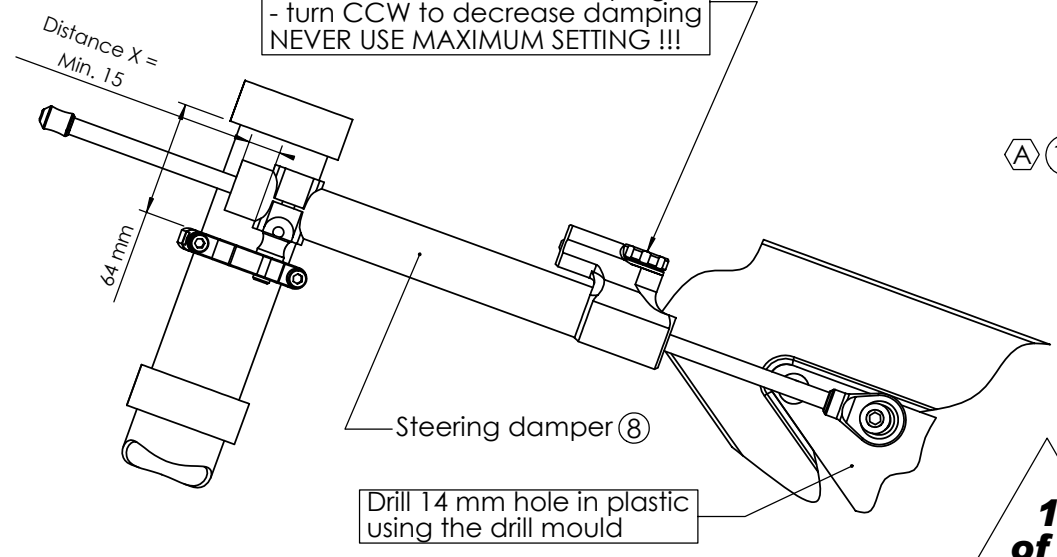

**1  
of 2**

(A)	14-17Nm / 124-150Lbs.In / 10.3-12.5Lbs.Ft	(C)	6Nm / 53Lbs.In / 4.4Lbs.Ft
(B)	8Nm / 70Lbs.In / 5.9Lbs.Ft		

**See WWW.HYPERPRO.COM for the latest pictures, modifications, specs. and e-drawings of this steering damper kit.**

# HYPERPRO

## STEERING DAMPER MOUNTING KIT

for

### YAMAHA YZF 600 R6 Race Model 1999 - 2002<

#### MK-YA06-S001 INSTALLATION INSTRUCTIONS

##### **In general:**

HYPERPRO can not be held responsible in any way for any form of physical, material, financial or other damage arising from use, assembly or overhaul of HYPERPRO products. HYPERPRO reserves the right to make changes without prior notice.

This product is ONLY TO BE INSTALLED BY A PROFESSIONAL MECHANIC.

This product is only to be used for the motorcycle brand, model and year stated specifically on top of the pages of this manual.

DO NOT attempt to install this product on motorcycles from any different brand, model and/or year than stated on the pages of this manual.

DO NOT use this kit for cars, boats, jet-skis, snowmobiles, ATV's, aircraft, hovercrafts or any other vehicle and/or purpose.

HYPERPRO steering dampers are FOR RACE USE ONLY, NOT FOR HIGHWAY USE!

##### **Before installation:**

- Please read the entire manual carefully before starting the installation!
- Check if you have all the tools required. Good tools are a must.
- Protect your bike at the most important places in and around the work area (e.g. tank, fairing, frame, etc.), with a blanket, towel or similar.

##### **During installation:**

- Check all operations and parts carefully before, during and after performing each step.
- Clean all surfaces that are required for fitting parts together or for applying self adhesives or loctite, thoroughly with contact cleaner or another degreaser, unless otherwise stated.
- Be careful not to damage or scratch any part of your bike.
- ALWAYS work relaxed and concentrated!! It is very easy to damage something or make a mistake.

##### **After installation:**

- Check and make sure that there is no contact between any part of the steering damper kit and any part of the motorcycle. The kit should not hit anything. Steering movement should not be limited by the steering damper. If the steering movement is limited, adjust the position of the tube in the clamp until steering movement is normal again. Do not forget to tighten the clamp bolt again!
- ALWAYS check the steering movement and feeling before each ride!
- FIRST RIDES: Start with the damper turned fully open (turn adjuster knob fully counter clockwise). Start adjusting in between rides with steps of MAX. 2 CLICKS (0.25 TURN) EACH TIME, until the damper is working satisfactory for your riding style.
- NEVER USE MAXIMUM SETTING, ALWAYS OPEN AT LEAST 2 CLICKS (0.25 TURN).

- WARNING ! DAMPER HAS AN ACTIVE / SPEEDSENSITIVE DAMPING SYSTEM;
  - Steering with NORMAL MOVEMENT should be FREE !!
  - Steering with FAST MOVEMENT should be CONTROLLED BY DAMPER !!
- HYPERPRO uses a special seal to reduce friction. The seal uses an oil film to work properly. It is normal that some oil can appear on the pistonrod.
- Damper works with oil: DAMPING CAN BE HARDER AT LOWER TEMPERATURES!

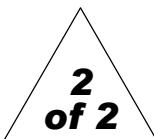

##### **Step 1: installing the fork bracket**

- Fork bracket  $\varnothing$ 43 (1)

Remove the 2 M5 clamp bolts (2) from the fork bracket assembly (1). Place the two halves around the left forkleg, approx. 64 mm below the upper triple clamp. Make sure that the 'furthest' hole (3) is on the frontside of the bike and reposition the bolts. Position under 10° from riding direction as shown on the picture on page 1. Tighten the bolts with a torque of approx. 8Nm/70Lbs.In/5.9Lbs.Ft

##### **Step 2: Installing the tube clamp**

- Spacer type 1 (4)
- 1x O-Ring (5)
- Tube Clamp TYPE 1 (6)
- Bolt M8x35 (7)

Put the assembly together as shown on page 1: Take the fork bracket (1), place the spacer (4), the O-ring (5) and the tube clamp (6) inline on top of the "nearest" M8 hole (3) and put the M8 bolt (7) through all the parts and screw it into the thread of the bracket. Tighten the bolt with a torque of approx. 14-17Nm/124-150Lbs.In/10.3-12.5Lbs.Ft.

##### **Step 3: The plastic frame cover**

Remove the fairing on the left hand side of the bike necessary to fit the frame bracket. Drill at 21 mm hole in the (black) plastic using the drill mould. Mount the frame bracket and assemble the fairing using the original bolts.

##### **Step 4: installing the steering damper**

- Steering damper (8)
- O-ring (9)
- Washer M8 21 h=4 (10)
- Frame plug (11)
- Bolt M8x30 button head (12)

Ensure that the clamp bolt of the Tube clamp is pointing up. Shove the damper (8), through the clamp until the ball joint can be fitted to the frame beam. Use O-ring (9), washer (10), frame plug (11) and M8 bolt (12) to fixate the balljoint to the frame and tighten with a torque of approx. 14-17Nm/124-150Lbs.In/10.3-12.5Lbs.Ft. Position the damper tube until the minimal distance "X" stated on page 1 is reached, make sure that the damper has at least 2 mm clearance at full steering lock. Tighten the M6 clamp bolt (13) with a torque of approx. 6Nm/53Lbs.In/4.4Lbs.Ft.

Check if the damper does not touch anything (fairing, tacho) when steering from left to right. Adjust the height of the forkclamp to improve position / movement of the steering damper. Check if the bike can make it's full steering angle from left to right.

**See [WWW.HYPERPRO.COM](http://WWW.HYPERPRO.COM) for the latest pictures, modifications, specs. and e-drawings of this steering damper kit.**