

HYPHERPRO

STEERING DAMPER MOUNTING KIT

Replacement of original for SUZUKI
GSX-R 600 '01-'03, '04-'05, '06-'07
GSX-R 750 '00-'03, '04-'05, '06-'07
GSXR 1000 '01-'02, '03-'05, '05-'06<
GSXR 1300 Hayabusa 2008>

MK-SU07-0002 PART LIST

SD stroke 75	1	-	-
Tube Clamp TYPE 1	1	-	-
O-Ring	2	-	-
M8x30 Button head	1	-	-
M8x35 Button head	1	-	-
Washer M8 ϕ 16	3	-	-
Lock nut M8	1	-	-
-	-	-	-

ALL IDEAS, DESIGNS ARRANGEMENTS AND PLANS INDICATED OR REPRESENTED BY THIS DRAWING ARE OWNED BY HYPERPRO AND WERE CREATED, EVOLVED AND DEVELOPED FOR USE ON AND IN CONNECTION WITH THE SPECIFIC PROJECT. NONE SUCH IDEAS, DESIGNS, ARRANGEMENTS OR PLANS SHALL BE USED BY OR DISCLOSED TO ANY PERSON, FIRM OR CORPORATION FOR ANY PURPOSE WHATSOEVER WITHOUT THE WRITTEN PERMISSION OF HYPERPRO.

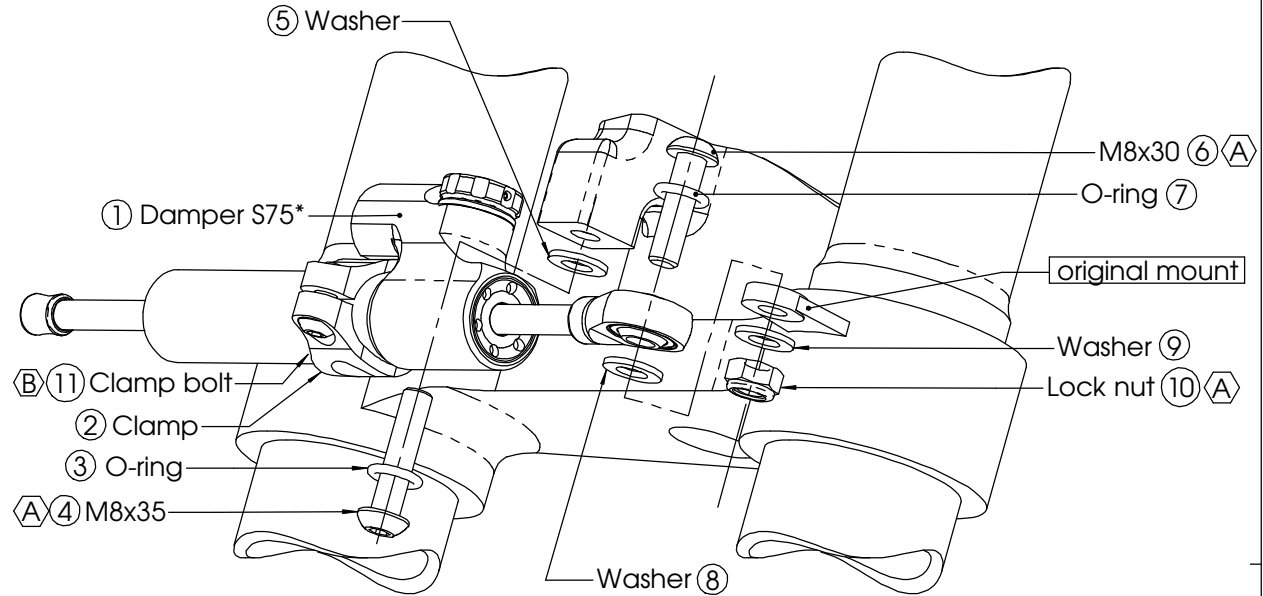

Damping adjustment knob
 - turn CW to increase damping,
 - turn CCW to decrease damping,
 Avoid using maximum setting.

Distance X= $\pm 62\text{mm}$

*NOTE: On some models it may be necessary to modify (bend) or remove the brake-line bracket for clearance

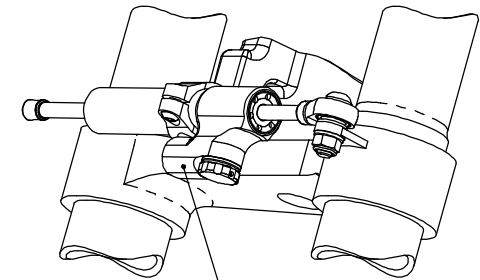
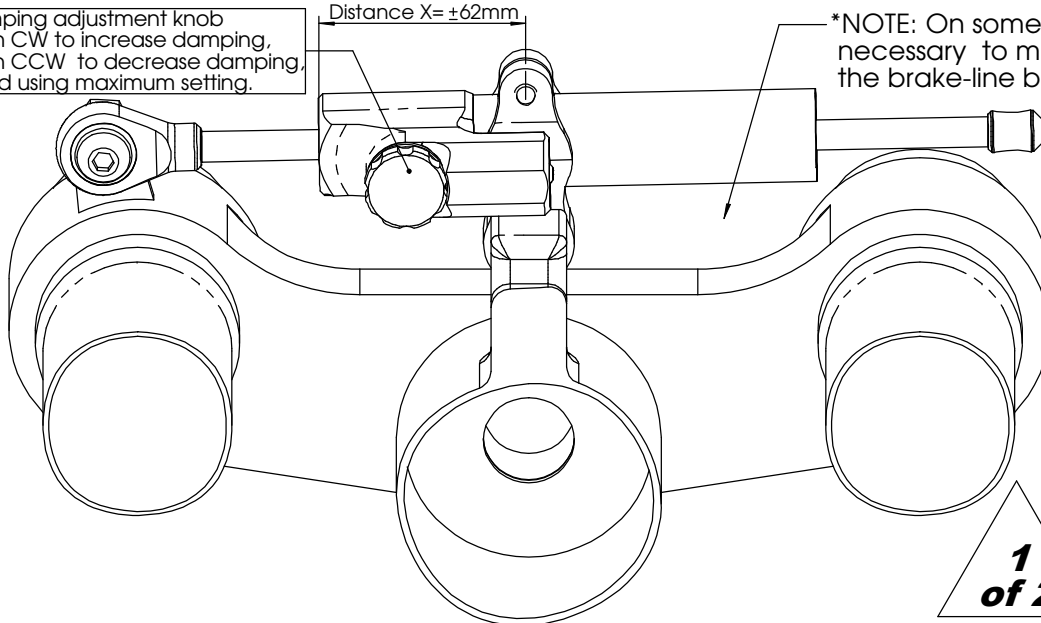

*NOTE: On some models it may be necessary to position the body underneath the clamp!

1
of 2

A	14-17Nm / 124-150Lbs.In / 10.3-12.5Lbs.Ft
B	6Nm / 53Lbs.In / 4.4Lbs.Ft

HYPERPRO

STEERING DAMPER MOUNTING KIT

Replacement of original for SUZUKI

GSX-R 600 '01-'03, '04-'05, '06-'07

GSX-R 750 '00-'03, '04-'05, '06-'07

GSXR 1000 '01-'02, '03-'05, '05-'06<

GSXR 1300 Hayabusa 2008>

MK-SU07-0002 INSTALLATION INSTRUCTIONS

In general:

HYPERPRO can not be held responsible in any way for any form of physical, material, financial or other damage arising from use, assembly or overhaul of HYPERPRO products. HYPERPRO reserves the right to make changes without prior notice.

This product is ONLY TO BE INSTALLED BY A PROFESSIONAL MECHANIC.

This product is only to be used for the motorcycle brand, model and year stated specifically on top of the pages of this manual.

DO NOT attempt to install this product on motorcycles from any different brand, model and/or year than stated on the pages of this manual.

DO NOT use this kit for cars, boats, jet-skies, snowmobiles, ATV's, aircraft, hovercrafts or any other vehicle and/or purpose.

HYPERPRO steering dampers are FOR RACE USE ONLY, NOT FOR HIGHWAY USE!

Before installation:

- Please read the entire manual carefully before starting the installation!
- Check if you have all the tools required. Good tools are a must.
- Protect your bike at the most important places in and around the work area (e.g. tank, fairing, frame, etc.), with a blanket, towel or similar.

During installation:

- Check all operations and parts carefully before, during and after performing each step.
- Clean all surfaces that are required for fitting parts together or for applying self adhesives or loctite, thoroughly with contact cleaner or another degreaser, unless otherwise stated.
- Be careful not to damage or scratch any part of your bike.
- ALWAYS work relaxed and concentrated!! It is very easy to damage something or make a mistake.

After installation:

- Check and make sure that there is no contact between any part of the steering damper kit and any part of the motorcycle. The kit should not hit anything. Steering movement should not be limited by the steering damper. If the steering movement is limited, adjust the position of the tube in the clamp until steering movement is normal again. Do not forget to tighten the clamp bolt again!
- ALWAYS check the steering movement and feeling before each ride!
- FIRST RIDES: Start with the damper turned fully open (turn adjuster knob fully counter clockwise). Start adjusting in between rides with steps of MAX. 2 CLICKS (0.25 TURN) EACH TIME, until the damper is working satisfactory for your riding style.
- NEVER USE MAXIMUM SETTING, ALWAYS OPEN AT LEAST 2 CLICKS (0.25 TURN).
- WARNING ! DAMPER HAS AN ACTIVE / SPEEDSENSITIVE DAMPING SYSTEM;
 - Steering with NORMAL MOVEMENT should be FREE !!
 - Steering with FAST MOVEMENT should be CONTROLLED BY DAMPER !!
- HYPERPRO uses a special seal to reduce friction. The seal uses an oil film to work properly. It is normal that some oil can appear on the pistonrod.
- Damper works with oil: DAMPING CAN BE HARDER AT LOWER TEMPERATURES!

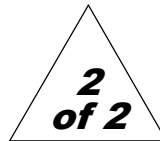

Step 1: REMOVE THE STANDARD STEERING DAMPER FROM THE BIKE !!!

Step 2: damper + clamp pre-assembly

Pre-assemble the damper and clamp using:

- Steering damper (1)
- Tube clamp TYPE 1 (2)

Place the damper in the tube clamp, as shown on page 1.

NOTE: For GSXR1000 K5, K6 and 600/750 K6, K7, position the body UNDERNEATH the clamp.

Position the clamp until the distance X is reached (± 62mm).

Then tighten the M6 clamp bolt (11) with a torque of 6Nm/53Lbs.In/4.4Lbs.Ft.

Step 3: installing the clamp to the frame

Install clamp using:

- Damper pre-assembly (1)+(2)
- 1x O-Ring (3)
- Bolt M8x35 button head (4)
- 1x Washer M8 Ø 16 (5)

Position the parts in the correct order (see page 1) in the damper clamp. Fit the parts to the original M8 hole in the bottom of the cockpit frame and tighten with a torque of approx. 14-17Nm/124-150Lbs.In/10.3-12.5Lbs.Ft. We advise to use Loctite or a similar threadlock.

Step 4: installing the damper head to the fork

Install the steering damper using:

- Bolt M8x30 button head (6)
- 1x O-ring (7)
- 2x Washer M8 Ø 16 (8)&(9)
- Lock nut M8 (10)

Use the M8x30 bolt (6), O-ring (7), washers (8)&(9) and M8 Lock nut (10) to fixate the balljoint to the left forkleg as shown on page 1 and tighten with a torque of approx. 14-17Nm/124-150Lbs.In/10.3-12.5Lbs.Ft. Check if the bike can make it's full steering angle from left to right. IF NOT, re-position the damper tube in the clamp, then re-tighten the M6 clamp bolt (11) with a torque of approx. 6Nm/53Lbs.In/4.4Lbs.Ft. Check again if the bike can make it's full steering angle from left to right.

Modify / Bend the brake-line bracket a little bit if necessary to create more clearance or completely remove the bracket and replace it with a zip-tie or similar.