

HYPERPRO

STEERING DAMPER MOUNTING KIT

for

KAWASAKI ZX-9R Model 1994 - 1997<

MK-KA09-T001 PART LIST

SD stroke 75	1	M6x40	1
Tube Clamp TYPE 1	1	Washer M8 Ø 16	4
O-Ring	2	Washer M6 Ø 12	1
Fork Bracket	1	-	-
Tank Bracket	1	-	-
M8x30 Button head	2	-	-
M8x50 Button head	2	-	-
M6x30	2	SD Reversal manual	1

ALL IDEAS, DESIGNS ARRANGEMENTS AND PLANS INDICATED OR REPRESENTED BY THIS DRAWING ARE OWNED BY HYPERPRO AND WERE CREATED, EVOLVED AND DEVELOPED FOR USE ON AND IN CONNECTION WITH THE SPECIFIC PROJECT. NONE SUCH IDEAS, DESIGNS, ARRANGEMENTS OR PLANS SHALL BE USED BY OR DISCLOSED TO ANY PERSON, FIRM OR CORPORATION FOR ANY PURPOSE WHATSOEVER WITHOUT THE WRITTEN PERMISSION OF HYPERPRO.

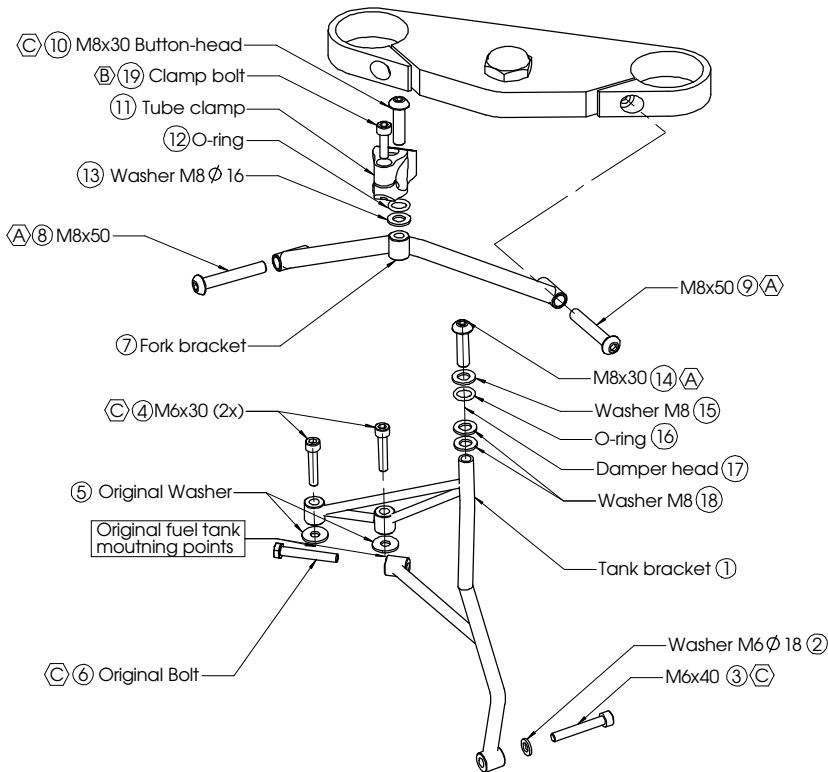
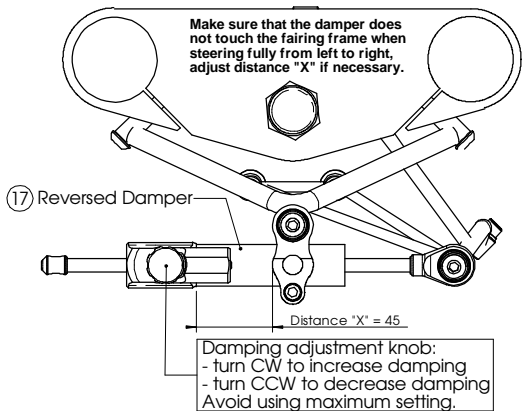

1
of 2

- A 14-17Nm / 124-150Lbs.In / 10.3-12.5Lbs.Ft
 C 5-9Nm / 44-80Lbs.In / 4.0-6.4Lbs.Ft
B 6Nm / 53Lbs.In / 4.4Lbs.Ft

See WWW.HYPERPRO.COM for the latest pictures, modifications, specs. and e-drawings of this steering damper kit.

HYPERPRO

STEERING DAMPER MOUNTING KIT

for

KAWASAKI ZX-9R Model 1994 - 1997<

MK-KA09-T001 INSTALLATION INSTRUCTIONS

In general:

HYPERPRO can not be held responsible in any way for any form of physical, material, financial or other damage arising from use, assembly or overhaul of HYPERPRO products. HYPERPRO reserves the right to make changes without prior notice.

This product is ONLY TO BE INSTALLED BY A PROFESSIONAL MECHANIC. This product is only to be used for the motorcycle brand, model and year stated specifically on top of the pages of this manual.

DO NOT attempt to install this product on motorcycles from any different brand, model and/or year than stated on the pages of this manual.

DO NOT use this kit for cars, boats, jet-skies, snowmobiles, ATV's, aircraft, hovercrafts or any other vehicle and/or purpose.

HYPERPRO steering dampers are FOR RACE USE ONLY, NOT FOR HIGHWAY USE!

Before installation:

- Please read the entire manual carefully before starting the installation!
- Check if you have all the tools required. Good tools are a must.
- Protect your bike at the most important places in and around the work area (e.g. tank, fairing, frame, etc.), with a blanket, towel or similar.

During Installation:

- Check all operations and parts carefully before, during and after performing each step.
- Clean all surfaces that are required for fitting parts together or for applying self adhesives or loctite, thoroughly with contactcleaner or another degreaser, unless otherwise stated.
- Be careful not to damage or scratch any part of your bike.
- ALWAYS work relaxed and concentrated!! It is very easy to damage something or make a mistake.

After installation:

- Check and make sure that there is no contact between any part of the steering damper kit and any part of the motorcycle. The kit should not hit anything. Steering movement should not be limited by the steering damper. If the steering movement is limited, adjust the position of the tube in the clamp until steering movement is normal again. Do not forget to tighten the clamp bolt again!
- ALWAYS check the steering movement and feeling before each ride!
- FIRST RIDES: Start with the damper turned fully open (turn adjuster knob fully counter clockwise). Start adjusting in between rides with steps of MAX. 2 CLICKS (0.25 TURN) EACH TIME, until the damper is working satisfactory for your riding style.
- NEVER USE MAXIMUM SETTING, ALWAYS OPEN AT LEAST 2 CLICKS (0.25 TURN).
- WARNING! DAMPER HAS AN ACTIVE / SPEEDSENSITIVE DAMPING SYSTEM;
 - Steering with NORMAL MOVEMENT should be FREE !!
 - Steering with FAST MOVEMENT should be CONTROLLED BY DAMPER !!
- HYPERPRO uses a special seal to reduce friction. The seal uses an oil film to work properly. It is normal that some oil can appear on the pistonrod.
- Damper works with oil: DAMPING CAN BE HARDER AT LOWER TEMPERATURES!



Step 1: Installing the tank bracket

- 2x Bolt M6x30 (4)
- Washers M6 Ø12 (2)
- Bolt M6x40 (3)
- Tank bracket (1)

Remove the 4 original bolts and washers from the front tank mounting points and the front (sub) frame. Use the supplied M6x30 (4) and M6x40 bolts (3), washer M6 (2), the original bolt (6) and the original washers (5) to install the tank bracket (1). Put the assembly together as shown in the right picture on page 1. Tighten the bolts with a torque of approx. 5-9Nm/44-80Lbs.In/4.0-6.4Lbs.Ft

Step 2: Installing the fork bracket

- Fork bracket (7)
- 2x Bolt M8x50 (8 & 9)

Loosen and remove the two front leg bolts on the upper triple tree. Place the fork bracket (7) in the mounting holes and use the two supplied M8x50 bolts (8 & 9) to mount the bracket in the upper triple tree. Tighten carefully with a torque of approx. 14-17Nm/124-150Lbs.In/10.3-12.5Lbs.Ft.

Step 3: fork bracket assembly

- Fork bracket (7)
- Bolt M8x30 Button head (10)
- TubeClamp TYPE 1 (11)
- 1x O-Ring (12)
- Washer M8 Ø16 (13)

Put the assembly together as shown on page 1: On the fork bracket (7), use the M8 bolt (10) to mount the tube clamp (11), O-ring (12) and washer (13), on the M8 hole. Tighten the bolt with a torque of approx. 14-17Nm/124-150Lbs.In/10.3-12.5Lbs.Ft.

Step 4: installing the steering damper

- Bolt M8x30 button head (14)
- Steering damper, REVERSED (17)
- 1x O-ring (16)
- Washer M8 Ø16 (15 & 18)

Ensure that the clamp bolt (19) of the tube clamp is pointing backward. Shove the damper (17), with the end-knob first, through the clamp until the balljoint can be fitted to the tank bracket (1). Put the assembly together as shown on page 1, add washer(s) (18) if necessary for horizontal position of the steering damper. Use the M8 bolt (14) to fixate the balljoint, O-ring (16) and washers (15 & 18) to the tank bracket and tighten with a torque of approx. 14-17Nm/124-150Lbs.In/10.3-12.5Lbs.Ft. Move the damper tube until the distance "X" (=63mm) stated on page 1 is reached, then tighten the M6 clamp bolt (19) with a torque of approx. 6Nm/53Lbs.In/4.4Lbs.Ft. Make sure the damper does not touch the fairing frame and the damper should never reach the end of its stroke when steering fully from left to right, adjust distance "X" if necessary.

Check if the damper is level horizontally and aligned to the bike. Check if the damper does not touch anything (e.g. tank) when steering from left to right. Check if the bike can make it's full steering angle from left to right.

See WWW.HYPERPRO.COM for the latest pictures, modifications, specs. and e-drawings of this steering damper kit.