

HYPHERPRO

STEERING DAMPER MOUNTING KIT

for

Kawasaki Versys 650 (ABS) Model 2007 ->

MK-KA06-B008 PART LIST

SD stroke 75	1	Washer M8 ϕ 16	3
Tube Clamp (MP-DB018235)	1	Zip-tie	1
O-Ring	2	-	-
Fork Clamp ϕ 52 (MP-FC0520)	1	-	-
Frame Bracket (MP-FRMK27)	1	-	-
M8x25 Button head	2	-	-
M8x30	2	-	-
Lock nut M8	2	-	-

ALL IDEAS, DESIGNS ARRANGEMENTS AND PLANS INDICATED OR REPRESENTED BY THIS DRAWING ARE OWNED BY HYPERPRO AND WERE CREATED, EVOLVED AND DEVELOPED FOR USE ON AND IN CONNECTION WITH THE SPECIFIC PROJECT. NONE SUCH IDEAS, DESIGNS, ARRANGEMENTS OR PLANS SHALL BE USED BY OR DISCLOSED TO ANY PERSON, FIRM OR CORPORATION FOR ANY PURPOSE WHATSOEVER WITHOUT THE WRITTEN PERMISSION OF HYPERPRO.

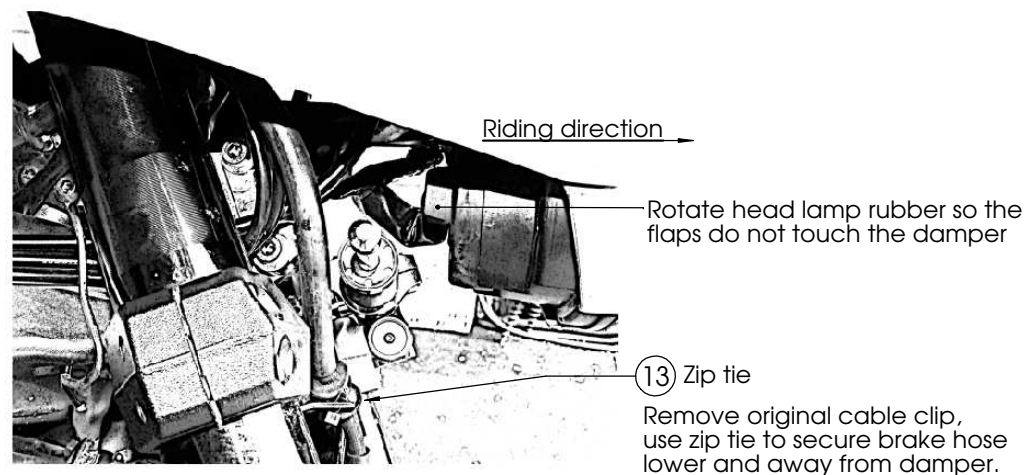
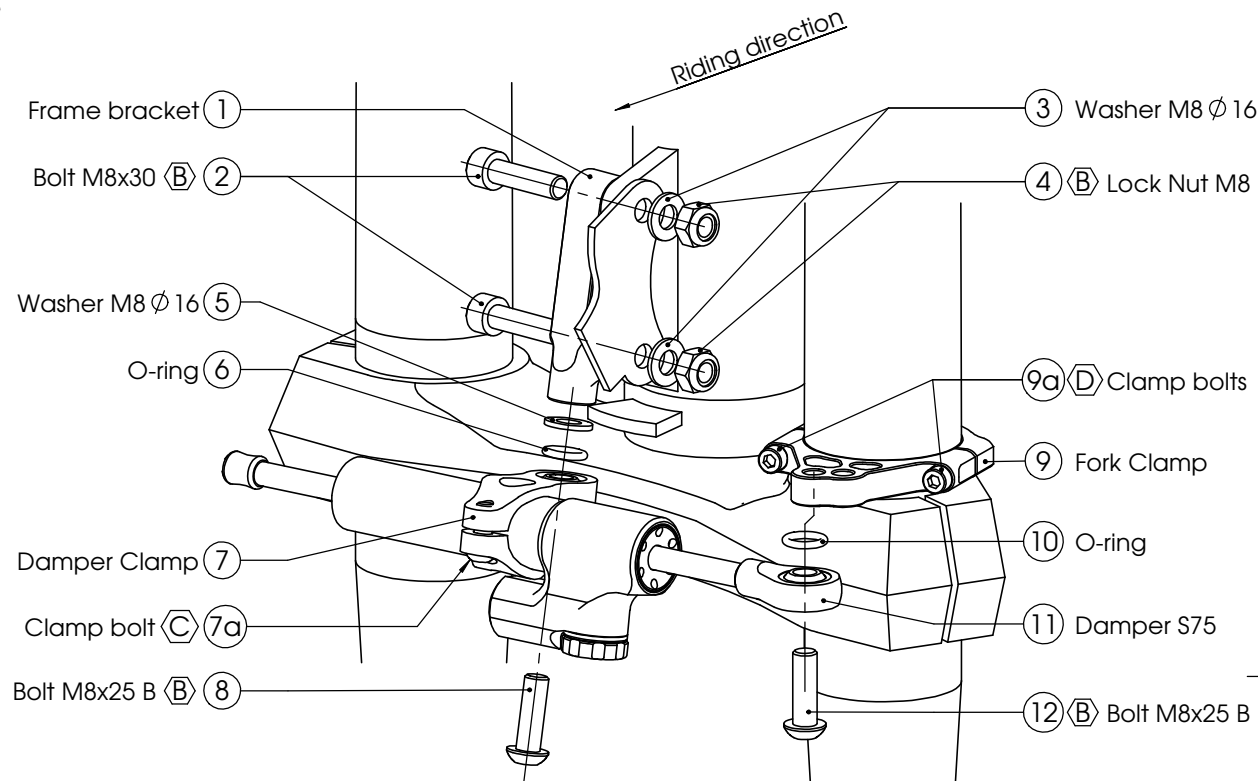
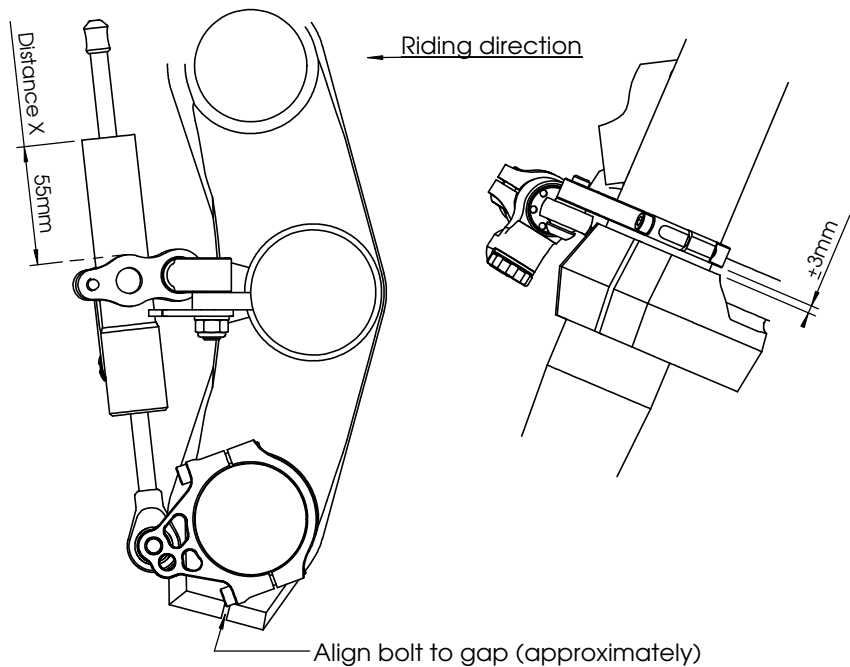

TORQUES

A: 5-9Nm / 44-80Lbs.In / 4.0-6.4Lbs.Ft
 B: 14-17Nm / 124-150Lbs.In / 10.3-12.5Lbs.Ft
 C: 6Nm / 53Lbs.In / 4.4Lbs.Ft

D: 8Nm / 70Lbs.In / 5.9Lbs.Ft
 E: 55Nm / 486Lbs.In / 40Lbs.Ft
 F: Factory torque (see owners manual)

HYPERPRO

STEERING DAMPER MOUNTING KIT

for

Kawasaki Versys 650 (ABS) Model 2007 ->

MK-KA06-B008 INSTALLATION INSTRUCTIONS

In general:

HYPERPRO can not be held responsible in any way for any form of physical, material, financial or other damage arising from use, assembly or overhaul of HYPERPRO products. HYPERPRO reserves the right to make changes without prior notice.

This product is ONLY TO BE INSTALLED BY A PROFESSIONAL MECHANIC.

This product is only to be used for the motorcycle brand, model and year stated specifically on top of the pages of this manual.

DO NOT attempt to install this product on motorcycles from any different brand, model and/or year than stated on the pages of this manual.

DO NOT use this kit for cars, boats, jet-skies, snowmobiles, ATV's, aircraft, hovercrafts or any other vehicle and/or purpose.

HYPERPRO steering dampers are FOR RACE USE ONLY, NOT FOR HIGHWAY USE!

Before installation:

- Please read the entire manual carefully before starting the installation!
- Check if you have all the tools required. Good tools are a must.
- Protect your bike at the most important places in and around the work area (e.g. tank, fairing, frame, etc.), with a blanket, towel or similar.

During installation:

- Check all operations and parts carefully before, during and after performing each step.
- Clean all surfaces that are required for fitting parts together or for applying self adhesives or loctite, thoroughly with contact cleaner or another degreaser, unless otherwise stated.
- Be careful not to damage or scratch any part of your bike.
- ALWAYS work relaxed and concentrated!! It is very easy to damage something or make a mistake.

After installation:

- Check and make sure that there is no contact between any part of the steering damper kit and any part of the motorcycle. The kit should not hit anything. Steering movement should not be limited by the steering damper. If the steering movement is limited, adjust the position of the tube in the clamp until steering movement is normal again. Do not forget to tighten the clamp bolt again!
- ALWAYS check the steering movement and feeling before each ride !
- FIRST RIDES: Start with the damper turned fully open (turn adjuster knob fully counter clockwise). Start adjusting in between rides with steps of MAX. 2 CLICKS (0.25 TURN) EACH TIME, until the damper is working satisfactory for your riding style.
- NEVER USE MAXIMUM SETTING, ALWAYS OPEN AT LEAST 2 CLICKS (0.25 TURN).
- WARNING ! DAMPER HAS AN ACTIVE / SPEEDSENSITIVE DAMPING SYSTEM;
 - Steering with NORMAL MOVEMENT should be FREE !!
 - Steering with FAST MOVEMENT should be CONTROLLED BY DAMPER !!
- HYPERPRO uses a special seal to reduce friction. The seal uses an oil film to work properly. It is normal that some oil can appear on the pistonrod.
- Damper works with oil: DAMPING CAN BE HARDER AT LOWER TEMPERATURES!

Step 1: install the frame bracket

Install the tank bracket using:

- Frame bracket (1)
- 2x Bolt M8x30 (2)
- 2x Washer M8 ϕ 16 (3)
- 2x Lock nut M8 (4)

Remove the plastic brake hose clip from the triple clamp (see page 1, number 13).

Install the frame bracket (1) to the Right side of the steering head - cockpit frame mounts, behind the headlamp. Loosen the two original M8 nuts and fit the M8 bolts (2) through the bracket (1) and the frame mounting holes, replacing the original bolts one by one.

Place a washer (3) and a nut (4) on the opposite side and tighten the bolts & nuts to a torque of approx. 14-17Nm/124-150Lbs.In/10.3-12.5Lbs.Ft.

Step 2: install the damper clamp

Install the damper clamp using:

- Washer M6 ϕ 12 (5)
- 1x O-Ring (6)
- Damper Clamp (7)
- Bolt M8x25 button head (8)

Put the assembly together as shown on page 1:

Use the bolt (8) to install the washer (5), the O-ring (6) and the damper clamp (7) to the bracket (1). Tighten the bolt with a torque of approx. 14-17Nm/124-150Lbs.In/10.3-12.5Lbs.Ft.

Step 3: install the fork clamp

- Fork clamp ϕ 52 (9)

Remove the two M5 clamp bolts (9a) from the bracket (9). Assemble the bracket parts around the left fork leg, 3mm above the top of the lower triple clamp. Make sure that the hole with the least distance is pointing outwards and align the left clamp bolt to the triple clamp as shown on page 1. Replace the clamp bolts and tighten them with a torque of approx. 8Nm/70Lbs.In/5.9Lbs.Ft

Step 4: installing the steering damper

Install the steering damper using:

- 1x O-ring (10)
- Steering damper, stroke 75 (11)
- Bolt M8x25 button head (12)
- Zip tie (13)

Shove the damper (11) through the clamp until the ball joint can be fitted to the fork clamp. Use the O-ring (10) and M8 bolt (12) to install the ball joint to the fork clamp and tighten with a torque of approx. 14-17Nm/124-150Lbs.In/10.3-12.5Lbs.Ft.

Position the damper tube until the distance "X" stated on page 1 is reached, position the damper body as shown on the picture, then tighten the M6 clamp bolt (9a) with a torque of approx. 6Nm/53Lbs.In/4.4Lbs.Ft.

Use the zip tie (13) to refit the brake hose to the triple clamp, away from the damper.

Check if the damper is level horizontally and aligned to the bike. Check if the bike can make it's full steering angle from left to right. Adjust "distance X" and/or the position of the fork clamp