

HYPHERPRO

STEERING DAMPER MOUNTING KIT

for

HONDA CBR600RR
Model 2005 - 2006<

MK-HO06-T007 PART LIST

SD stroke 75	1	Washer M6 ϕ 12	1
Tube Clamp TYPE 3	1	Washer M6 ϕ 18	2
O-Ring	2	Washer M8 ϕ 16	1
CNC Fork Bracket	1	-	-
CNC Tank Bracket	1	-	-
M8x25 Button head	1	-	-
M6x20 Low head	1	-	-
M6x25 Button head	2	-	-

ALL IDEAS, DESIGNS ARRANGEMENTS AND PLANS INDICATED OR REPRESENTED BY THIS DRAWING ARE OWNED BY HYPERPRO AND WERE CREATED, EVOLVED AND DEVELOPED FOR USE ON AND IN CONNECTION WITH THE SPECIFIC PROJECT. NONE SUCH IDEAS, DESIGNS, ARRANGEMENTS OR PLANS SHALL BE USED BY OR DISCLOSED TO ANY PERSON, FIRM OR CORPORATION FOR ANY PURPOSE WHATSOEVER WITHOUT THE WRITTEN PERMISSION OF HYPERPRO.

DAMPING ADJUSTER KNOB:
- turn CW to increase damping
- turn CCW to decrease damping
NEVER USE MAXIMUM SETTING !!!

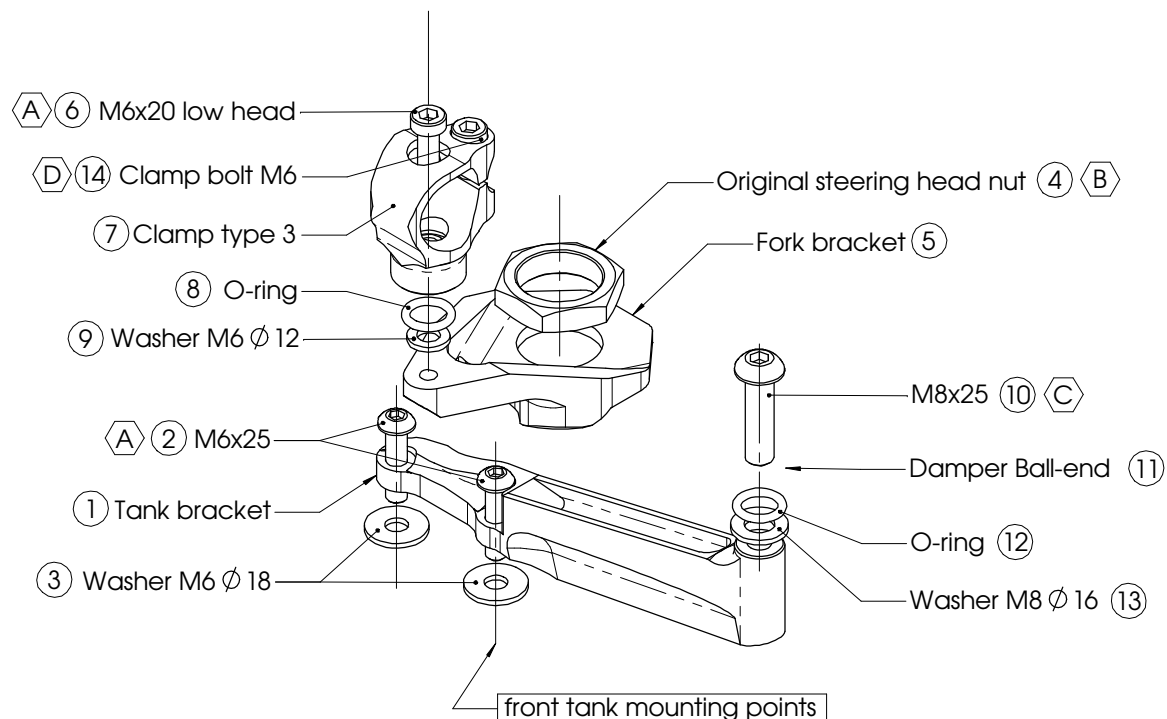
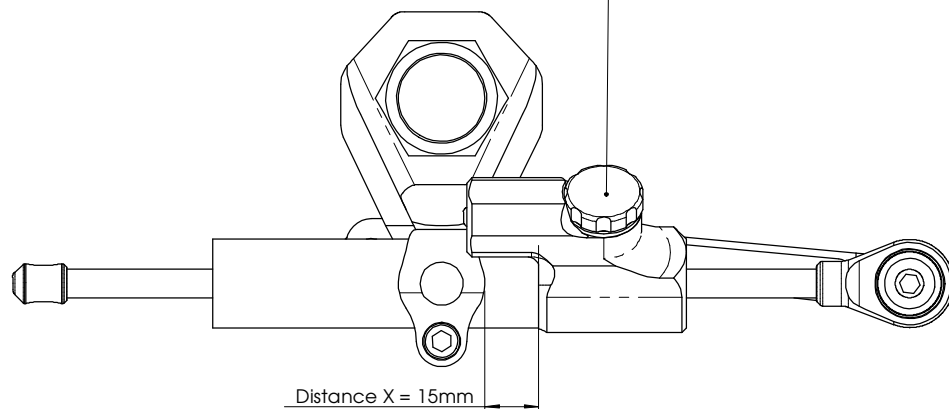

1
of 2

A 5-9Nm / 44-80Lbs.In / 4.0-6.4Lbs.Ft

B 55-75Nm/486-663Lbs.In/40-55Lbs.Ft

C 14-17Nm / 124-150Lbs.In / 10.3-12.5Lbs.Ft

D 6Nm / 53Lbs.In / 4.4Lbs.Ft

See WWW.HYPERPRO.COM for the latest pictures, modifications, specs. and e-drawings of this steering damper kit.

HYPERPRO

STEERING DAMPER MOUNTING KIT

for

HONDA CBR600RR Model 2005 - 2006<

MK-HO06-T007 INSTALLATION INSTRUCTIONS

In general:

HYPERPRO can not be held responsible in any way for any form of physical, material, financial or other damage arising from use, assembly or overhaul of HYPERPRO products. HYPERPRO reserves the right to make changes without prior notice.

This product is ONLY TO BE INSTALLED BY A PROFESSIONAL MECHANIC.

This product is only to be used for the motorcycle brand, model and year stated specifically on top of the pages of this manual.

DO NOT attempt to install this product on motorcycles from any different brand, model and/or year than stated on the pages of this manual.

DO NOT use this kit for cars, boats, jet-skies, snowmobiles, ATV's, aircraft, hovercrafts or any other vehicle and/or purpose.

HYPERPRO steering dampers are FOR RACE USE ONLY, NOT FOR HIGHWAY USE!

Before installation:

- Please read the entire manual carefully before starting the installation!
- Check if you have all the tools required. Good tools are a must.
- Protect your bike at the most important places in and around the work area (e.g. tank, fairing, frame, etc.), with a blanket, towel or similar.

During installation:

- Check all operations and parts carefully before, during and after performing each step.
- Clean all surfaces that are required for fitting parts together or for applying self adhesives or loctite, thoroughly with contact cleaner or another degreaser, unless otherwise stated.
- Be careful not to damage or scratch any part of your bike.
- ALWAYS work relaxed and concentrated!! It is very easy to damage something or make a mistake.

After installation:

- Check and make sure that there is no contact between any part of the steering damper kit and any part of the motorcycle. The kit should not hit anything. Steering movement should not be limited by the steering damper. If the steering movement is limited, adjust the position of the tube in the clamp until steering movement is normal again. Do not forget to tighten the clamp bolt again!
- ALWAYS check the steering movement and feeling before each ride!
- FIRST RIDES: Start with the damper turned fully open (turn adjuster knob fully counter clockwise). Start adjusting in between rides with steps of MAX. 2 CLICKS (0.25 TURN) EACH TIME, until the damper is working satisfactory for your riding style.
- NEVER USE MAXIMUM SETTING, ALWAYS OPEN AT LEAST 2 CLICKS (0.25 TURN).

- WARNING ! DAMPER HAS AN ACTIVE / SPEEDSENSITIVE DAMPING SYSTEM;
 - Steering with NORMAL MOVEMENT should be FREE !!
 - Steering with FAST MOVEMENT should be CONTROLLED BY DAMPER !!
- HYPERPRO uses a special seal to reduce friction. The seal uses an oil film to work properly. It is normal that some oil can appear on the pistonrod.
- Damper works with oil: DAMPING CAN BE HARDER AT LOWER TEMPERATURES!

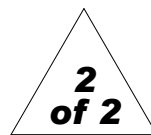

Step 1: installing the tank bracket

- Install the tank bracket using:
- Tank bracket (1)
 - 2x Bolt M6x25 button head (2)
 - 2x Washer M6 \varnothing 18 (3)

Remove the 2 standard M6 bolts from the front tank mounting points.

Install the tank bracket (1), using the 2 supplied M6x25 button head bolts (2), place the supplied M6 washers (3) underneath the bracket for support as shown in the right picture on page 1. Tighten the bolts with a torque of approx. 5-9Nm/44-80Lbs.In/4.0-6.4Lbs.Ft

Step 2: installing the fork bracket

- Install the fork bracket using:
- Fork bracket (5)

Loosen and remove the steering stem nut (4). Remove standard washer. Place the bracket (5) over the thread. Replace the nut on top of the fork clamp and tighten carefully with a torque of approx. 55-75Nm/486-663Lbs.In/40-55Lbs.Ft.

Step 3: installing the fork bracket

- Assemble the fork bracket using:
- Bolt M6x20 Low head (6)
 - TubeClamp TYPE 3 (7)
 - 1x O-Ring (8)
 - Washer M6 \varnothing 12 (9)

Put the assembly together as shown on page 1: Place the washer (9), the O-ring (8) and the tube clamp (7) inline on top of the M6 hole and use the M6 bolt (6) to tighten all the parts on the bracket (5). Tighten the bolt with a torque of approx. 5-9Nm/44-80Lbs.In/4.0-6.4Lbs.Ft.

Step 4: installing the steering damper

- Install the steering damper using:
- Bolt M8x25 button head (10)
 - Steering damper, stroke 75 (11)
 - 1x O-ring (12)
 - Washer M8 \varnothing 16 (13)

Ensure that the clamp bolt of the Tube clamp is pointing to the rear. Shove the damper (14), with the end knob-side first, through the clamp until the ball-joint can be fitted to the tank bracket. Use the washer (13), O-ring (12) and M8 bolt (10) to fixate the ball-joint to the tank bracket and tighten with a torque of approx. 14-17Nm/124-150Lbs.In/10.3-12.5Lbs.Ft.

Position the damper tube until the distance "X" stated on page 1 is reached, then tighten the M6 clamp bolt (14) with a torque of approx. 6Nm/53Lbs.In/4.4Lbs.Ft. Check if the damper is level horizontally and aligned to the bike. Check if the damper does not touch anything (e.g. tank) when steering from left to right. Check if the bike can make it's full steering angle from left to right.

See WWW.HYPERPRO.COM for the latest pictures, modifications, specs. and e-drawings of this steering damper kit.