

HYPHERPRO

STEERING DAMPER MOUNTING KIT for H-D SPORTSTER XL883 & XL1200 Models 2004>

MK-HD12-S002 PART LIST

SD stroke 120	1	Washer M8 ϕ 16	1
Fork Clamp ϕ 39	1	O-ring	2
Tube Clamp Type 1	1	-	-
Frame Clamp ϕ 35	1	-	-
Spacer Type 1	1	-	-
M6x30	1	-	-
M8x25 Button head	1	-	-
M8x70 Button head	1	-	-

ALL IDEAS, DESIGNS, ARRANGEMENTS AND PLANS INDICATED OR REPRESENTED BY THIS DRAWING ARE OWNED BY HYPERPRO AND WERE CREATED, EVOLVED AND DEVELOPED FOR USE ON AND IN CONNECTION WITH THE SPECIFIC PROJECT. NONE SUCH IDEAS, DESIGNS, ARRANGEMENTS OR PLANS SHALL BE USED BY OR DISCLOSED TO ANY PERSON, FIRM OR CORPORATION FOR ANY PURPOSE WHATSOEVER WITHOUT THE WRITTEN PERMISSION OF HYPERPRO.

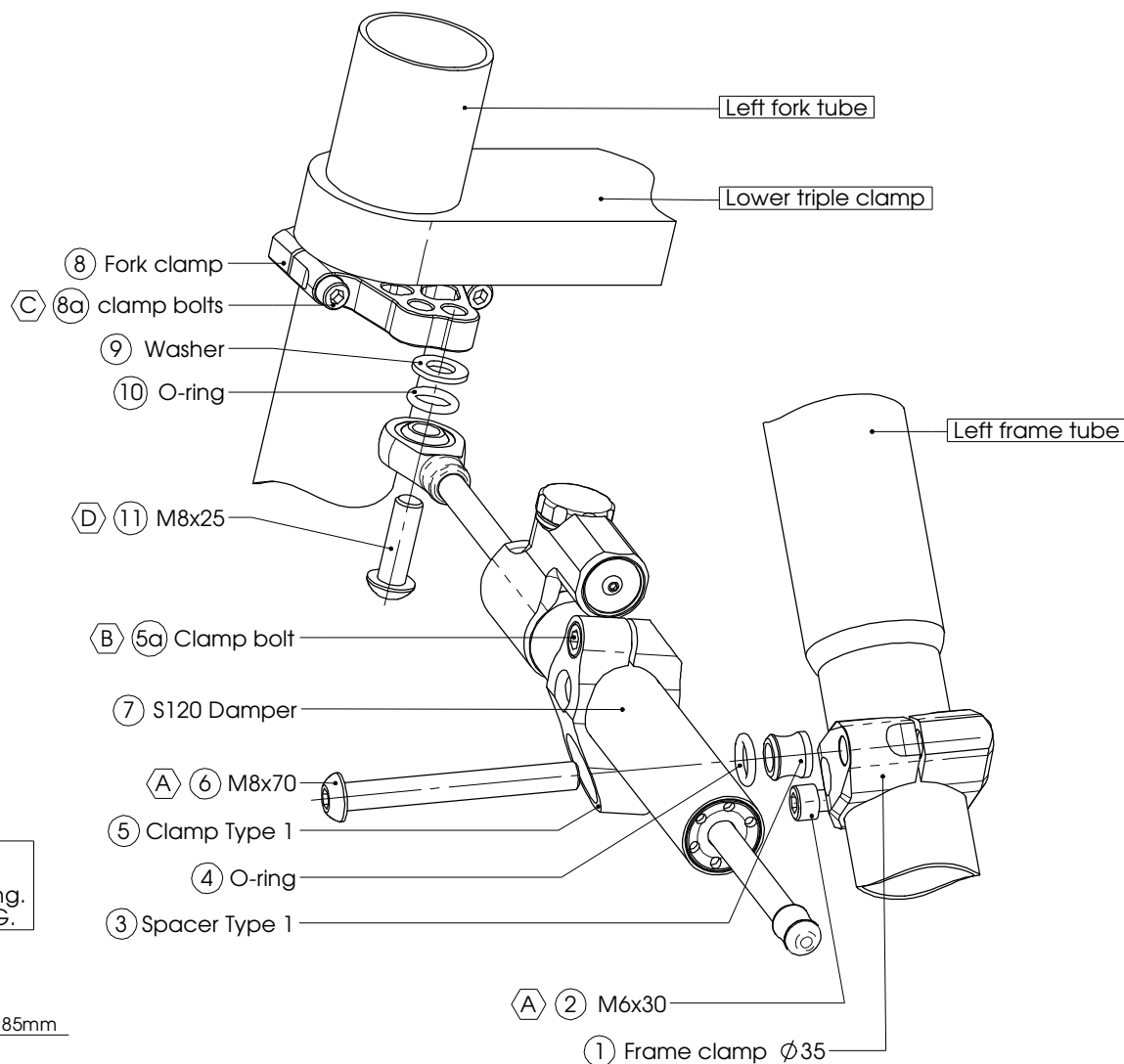
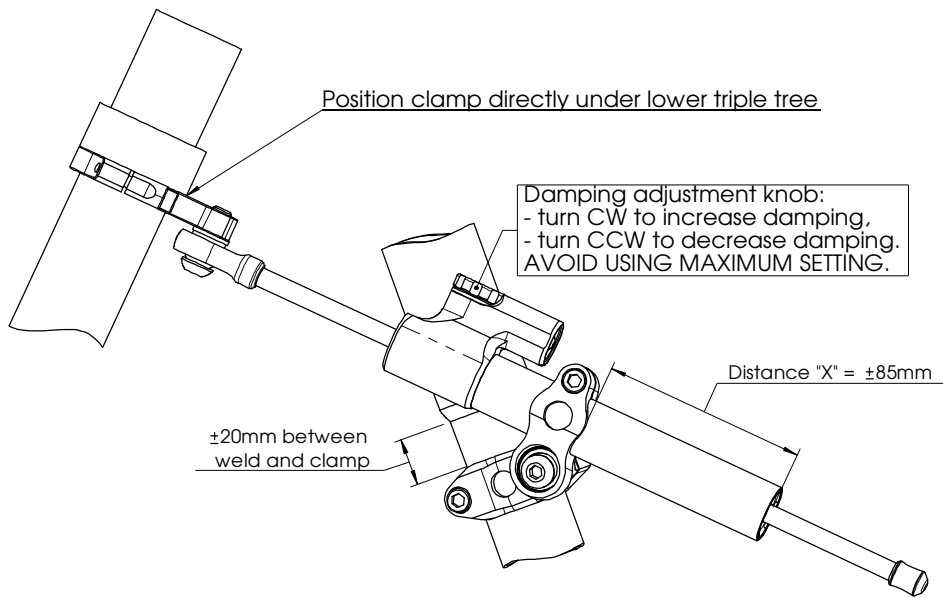

1
of 2

A 10Nm / 88Lbs.In / 7.4Lbs.Ft	C 8Nm / 70Lbs.In / 5.9Lbs.Ft
B 6Nm / 53Lbs.In / 4.4Lbs.Ft	D 14-17Nm / 124-150Lbs.In / 10.3-12.5Lbs.Ft

See WWW.HYPERPRO.COM for the latest pictures, modifications, specs. and e-drawings of this steering damper kit.

HYPERPRO

STEERING DAMPER MOUNTING KIT

for

H-D SPORTSTER XL883 & XL1200 Models 2004➤

MK-HD12-S002 INSTALLATION INSTRUCTIONS

In general:

HYPERPRO can not be held responsible in any way for physical, material, financial or other damage arising from use, assembly or overhaul of HYPERPRO products. HYPERPRO reserves the right to make changes without prior notice.

This product is ONLY TO BE INSTALLED BY A PROFESSIONAL MECHANIC.

This product is only to be used for the motorcycle brand, model and year stated specifically on top of the pages of this manual.

DO NOT attempt to install this product on motorcycles from any different brand, model and/or year than stated on the pages of this manual.

DO NOT use this kit for cars, boats, jet-skis, snowmobiles, ATV's, aircraft, hovercrafts or any other vehical and/or purpose.

HYPERPRO steering dampers are FOR RACE USE ONLY, NOT FOR HIGHWAY USE!

Before installation:

- Please read the entire manual carefully before starting the installation!
- Check if you have all the tools required. Good tools are a must.
- Protect your bike at the most important places in and around the work area (e.g. tank, fairing, frame, etc.) with a blanket, towel or similar.

During installation:

- Check all operations and parts carefully before, during and after performing each step.
- Clean all surfaces that are required for fitting parts together or for applying self adhesives or loctite, thoroughly with contactcleaner or another degreaser, unless otherwise stated.
- Be careful not to damage or scratch any part of your bike.
- ALWAYS work relaxed and concentrated!! It is very easy to damage something or make a mistake.

After installation:

- Check and make sure that there is no contact between any part of the steering damper kit and any part of the motorcycle. The kit should not hit anything. Steering movement should not be limited by the steering damper. If the steering movement is limited, adjust the position of the tube in the clamp until steering movement is normal again. Do not forget to tighten the clamp bolt again!
- ALWAYS check the steering movement and feeling before each ride !
- FIRST RIDES: Start with the damper turned fully open (turn adjuster knob fully counter clockwise). Start adjusting in between rides with steps of MAX. 2 CLICKS (0.25 TURN) EACH TIME, until the damper is working satisfactory for your riding style.
- NEVER USE MAXIMUM SETTING, ALWAYS OPEN AT LEAST 2 CLICKS (0.25 TURN).
- WARNING ! DAMPER HAS AN ACTIVE / SPEEDSENSITIVE DAMPING SYSTEM;
 - Steering with NORMAL MOVEMENT should be FREE !!
 - Steering with FAST MOVEMENT should be CONTROLLED BY DAMPER !!
- HYPERPRO uses a special seal to reduce friction. The seal uses an oil film to work properly. It is normal that some oil can appear on the pistonrod.
- Damper works with oil: DAMPING CAN BE HARDER AT LOWER TEMPERATURES!

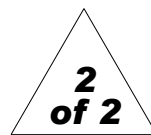

Step 1: installing the frame and damper clamp

Install the frame clamp assembly using:

- Frame clamp (1)
- Bolt M6x30 (2)
- Spacer Type 1 (3)
- 1x O-ring (4)
- Damper Clamp Type 1 (5)
- Bolt M8x70 (6)

Install the Frame clamp parts (1) around the left vertical frame tube, approximately 20mm below the weld. Make sure it is orientated correctly and use the M6x30 bolt (2) in the smaller hole. Fit the spacer (3), O-ring (4) and damper clamp (5) to the bigger hole, using the M8x70 bolt (6). Tighten the bolts (2) and (6) evenly with a torque of approx. 10Nm/88Lbs.In/7.4Lbs.Ft.

Step 2: installing the fork clamp

Install the fork clamp using:

- Fork clamp (8)

Disassemble the fork clamp. Re-assemble the parts around the left fork leg as shown on page 1, directly underneath the lower triple tree. Make sure it is aligned properly and tighten the clamp-bolts (8a) with a torque of approx. 8Nm/70Lbs.In/5.9Lbs.Ft

Step 3: installing the steering damper

Install the steering damper using:

- Steering damper, stroke 120 (7)
- Washer M8 Ø 16 (9)
- 1x O-ring (10)
- Bolt M8x25 button head (11)

Ensure that the clamp bolt of the tube clamp (5) is pointing upward. Shove the steering damper (7), with the knob-end first, through the clamp (5) until the ball-joint can be fitted to bottom of the fork-clamp (8). Use the washer (9), O-ring (10) and M8 bolt (11) to fit the ball-joint to the most outer hole and tighten with a torque of approx. 14-17Nm/124-150Lbs.In/10.3-12.5Lbs.Ft.

Position the damper tube until the distance "X" stated on page 1 is reached, then tighten the M6 clamp bolt (5a) with a torque of approx. 6Nm/53Lbs.In/4.4Lbs.Ft. Check if the damper is level aligned properly to the bike. Check if the damper does not touch anything (e.g. front cylinder) when steering from left to right. Check if the bike can make it's full steering angle from left to right.

Adjust the position and angle of the clamps if necessary, but do not forget to re-tighten the parts!

See WWW.HYPERPRO.COM for the latest pictures, modifications, specs. and e-drawings of this steering damper kit.