

HYPHERPRO

STEERING DAMPER MOUNTING KIT

for

**DUCATI 400/600/750/900
MONSTER HIGH '93 - '02<**

MK-DU04-S001 PART LIST

SD stroke 140	1	-	-
Tube Clamp Type 1	1	-	-
Fork Clamp $\varnothing 50$	1	-	-
Frame Clamp Type4	1	-	-
Spacer Type 1	2	-	-
O-ring	2	-	-
M8x35	1	-	-
M8x45	1	-	-

ALL IDEAS, DESIGNS ARRANGEMENTS AND PLANS INDICATED OR REPRESENTED BY THIS DRAWING ARE OWNED BY HYPHERPRO AND WERE CREATED, EVOLVED AND DEVELOPED FOR USE ON AND IN CONNECTION WITH THE SPECIFIC PROJECT. NONE SUCH IDEAS, DESIGNS, ARRANGEMENTS OR PLANS SHALL BE USED BY OR DISCLOSED TO ANY PERSON, FIRM OR CORPORATION FOR ANY PURPOSE WHATSOEVER WITHOUT THE WRITTEN PERMISSION OF HYPHERPRO.

DAMPING ADJUSTER KNOB:
- turn CW to increase damping
- turn CCW to decrease damping
NEVER USE MAXIMUM SETTING !!!

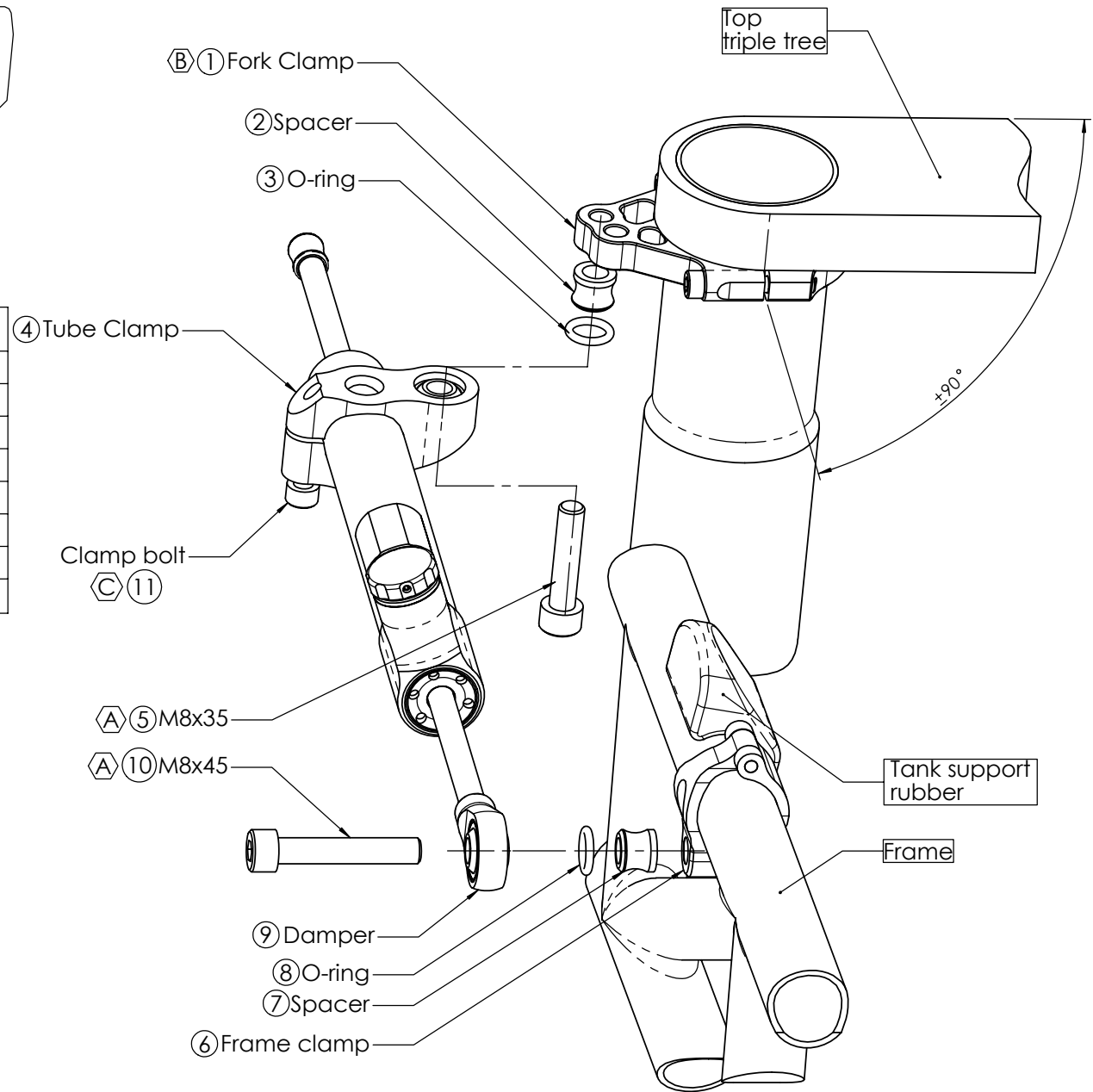
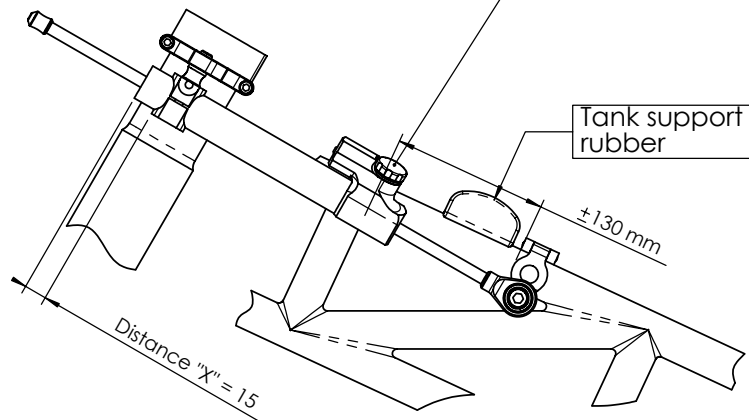

**1
of 2**

(A) 14-17Nm / 124-150Lbs.In / 10.3-12.5Lbs.Ft	(C) 6Nm / 53Lbs.In / 4.4Lbs.Ft
(B) 8Nm / 70Lbs.In / 5.9Lbs.Ft	

See WWW.HYPHERPRO.COM for the latest pictures, modifications, specs. and e-drawings of this steering damper kit.

HYPERPRO

STEERING DAMPER MOUNTING KIT

for

DUCATI 400/600/750/900 MONSTER HIGH '93 - '02<

MK-DU04-S001 INSTALLATION INSTRUCTIONS

In general:

HYPERPRO can not be held responsible in any way for any form of physical, material, financial or other damage arising from use, assembly or overhaul of HYPERPRO products. HYPERPRO reserves the right to make changes without prior notice.

This product is ONLY TO BE INSTALLED BY A PROFESSIONAL MECHANIC.

This product is only to be used for the motorcycle brand, model and year stated specifically on top of the pages of this manual.

DO NOT attempt to install this product on motorcycles from any different brand, model and/or year than stated on the pages of this manual.

DO NOT use this kit for cars, boats, jet-skis, snowmobiles, ATV's, aircraft, hovercrafts or any other vehicle and/or purpose.

HYPERPRO steering dampers are FOR RACE USE ONLY, NOT FOR HIGHWAY USE!

Before installation:

- Please read the entire manual carefully before starting the installation!
- Check if you have all the tools required. Good tools are a must.
- Protect your bike at the most important places in and around the work area (e.g. tank, fairing, frame, etc.), with a blanket, towel or similar.

During installation:

- Check all operations and parts carefully before, during and after performing each step.
- Clean all surfaces that are required for fitting parts together or for applying self adhesives or loctite, thoroughly with contact cleaner or another degreaser, unless otherwise stated.
- Be careful not to damage or scratch any part of your bike.
- ALWAYS work relaxed and concentrated!! It is very easy to damage something or make a mistake.

After installation:

- Check and make sure that there is no contact between any part of the steering damper kit and any part of the motorcycle. The kit should not hit anything. Steering movement should not be limited by the steering damper. If the steering movement is limited, adjust the position of the tube in the clamp until steering movement is normal again. Do not forget to tighten the clamp bolt again!
- ALWAYS check the steering movement and feeling before each ride!
- FIRST RIDES: Start with the damper turned fully open (turn adjuster knob fully counter clockwise). Start adjusting in between rides with steps of MAX. 2 CLICKS (0.25 TURN) EACH TIME, until the damper is working satisfactory for your riding style.
- NEVER USE MAXIMUM SETTING, ALWAYS OPEN AT LEAST 2 CLICKS (0.25 TURN).

- WARNING ! DAMPER HAS AN ACTIVE / SPEEDSENSITIVE DAMPING SYSTEM;
 - Steering with NORMAL MOVEMENT should be FREE !!
 - Steering with FAST MOVEMENT should be CONTROLLED BY DAMPER !!
- HYPERPRO uses a special seal to reduce friction. The seal uses an oil film to work properly. It is normal that some oil can appear on the pistonrod.
- Damper works with oil: DAMPING CAN BE HARDER AT LOWER TEMPERATURES!

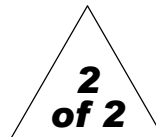

See WWW.HYPERPRO.COM for the latest pictures, modifications, specs. and e-drawings of this steering damper kit.

Remarks:

- Installation is shown for the left side of the bike. For installation to the right side, mirror all items!
- After installation, it might be necessary to adjust the max. steering angle limiters of the bike.

Step 1: installing the fork bracket

- Fork bracket \varnothing 50 (1)

Remove the 2 M5 clamp bolts from the bracket (1). Place the bracket parts around the fork leg, directly under the upper triple clamp. Make sure that the hole with the greatest distance is pointing fully outward (see picture on page 1).

Replace the clamp bolts and tighten them with a torque of approx. 8Nm/70Lbs.In/5.9Lbs.Ft

Step 2: installing the tube clamp

- 1x Spacer (2)
- 1x O-ring (3)
- Tube Clamp Type1 (4)
- Bolt M8x35 (5)

Put the assembly together as shown on page 1: place the spacer (2), the O-ring (3) and the tube clamp (5) inline on top of the fork clamp (1) and use the M8x35 bolt (5) to screw them together onto the fork clamp. Use the 'outer' hole. Tighten the bolt with a torque of approx. 14-17Nm/124-150Lbs.In/10.3-12.5Lbs.Ft.

Step 3: installing the frame clamp

- Frame clamp Type 4 (6)

Select the correct frame tube (see page 1). Clear any cable that might be in the way and fit the clamp around the frame tube, see the correct distance on page 1. Make sure that the drilled hole is on the outside, and the threaded hole is on the inside of the frame.

Step 4: installing the steering damper

- 1x Spacer (7)
- 1x O-ring (8)
- Steering damper (9)
- Bolt M8x45 (10)

Shove the damper (9), with the end knob-side first, through the tube clamp until the ball-joint can be fitted to the frame bracket. Use the spacer (7), O-ring (8) and M8 bolt (10) to fixate the balljoint to the frame clamp, but DO NOT TIGHTEN YET.

Position the damper tube until the distance "X" stated on page 1 is reached, leave the last 15 mm free! Tighten the M6 clamp bolt (11) with a torque of approx. 6Nm/53Lbs.In/4.4Lbs.Ft. Next adjust the frame clamp to ensure free travel of the damper tube and tighten the M8 bolt with a torque of approx. 14-17Nm/124-150Lbs.In/10.3-12.5Lbs.Ft.

Check if the damper does not touch anything (e.g. frame) when steering from left to right. Check if the bike can make its full steering angle from left to right.

If necessary, re-adjust the position of the fork and/or frame clamp(s). It might also be necessary to decrease maximum steering angle by adjusting the end-stops on the lower triple clamp of the bike.